



METPAR PLASTIC LAMINATE TOILET ENCLOSURES

Type F/C-FP/FP - Floor-To-Ceiling

- MATERIALS:** Plastic Laminate over particle board.
- THICKNESS:** Doors..... Finished to 1" (25.4mm) at 58" (1473) high
Panels..... Finished to 1" (25.4mm) at 58" (1473) high
Pilasters..... Finished to 1¼" (31.75mm) various heights

CONSTRUCTION:

Doors:

Finished to 1" (25.4) thick, constructed of .04" (1.02) post forming grade 12 decorative laminate over three-ply core, resin impregnated, 45-pound density particle board; *NEMA* approved and used exclusively. Edge laminates are applied before face laminates.

Panels:

Finished to 1" (25.4) thick, constructed of .04" (1.02) post forming grade 12 decorative laminate over three-ply core, resin impregnated, 45-pound density particle board; *NEMA* approved and used exclusively. Edge laminates are applied before face laminates.

Pilasters:

Finished to 1¼" (31.75) thick, constructed of .04" (1.02) post forming grade 12 decorative laminate over three-ply core, resin impregnated, 45 pound density particle board; *NEMA* approved and used exclusively. Edge laminates are applied before face laminates. All pilasters will have a 3" (76.2) high #4 finish stainless steel plinth and have a straight profile with square edges to match the pilaster profile. Pilasters are to be secured to the ceiling and floor with #12 x 2½" (63.5) screws and shields through a 16 gauge, hot-dipped galvanized channel fastened to both ends of the pilaster.

BRACKETS:

Wall and panel-to-pilaster brackets are chrome-plated zamac die castings. All wall connections must be with 1-ear or 2-ear brackets using a minimum of two (2) per connection. All panel-to-pilaster connections will use a U-bracket with a minimum of two (2) per connection.

DOOR HARDWARE:

Each compartment will be complete with all hardware, 2 door hinges, latch, stop and keeper, coat hook, as well as all necessary fittings and fastenings for a complete installation. Hinges and door strikes are fastened by means of tamper-proof Torx Pin Head through bolts, which are polished chrome plated. All other screws to be tamper-proof Torx Pin Head chrome plated. Doors are to be hung on concealed gravity hinges. Upper hinge shall use a 3/8" (9.525) diameter steel pin. All hinges will have wrap-around flanges with a minimum of 5/8" (15.875) wrap onto all pilasters.

OPTIONAL:

Full length clear anodized aluminum privacy strips to conceal gaps between doors and pilasters. Stainless steel surface mounted hinges or full length stainless steel MultiCam® hinges, both with stainless steel surface latch, S&K.



95 State Street, Westbury, NY 11590 ~ T: 516-333-2600 ~ F: 516-333-2618 ~ Metpar.com ~ Service@Metpar.com

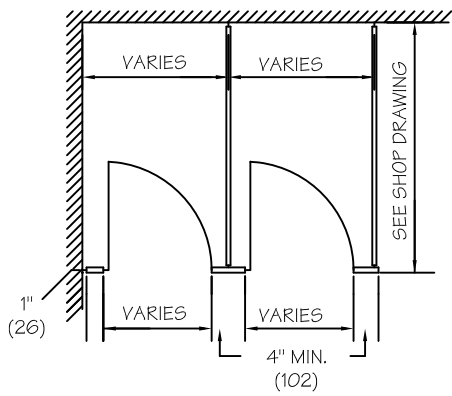

FLOOR PLAN

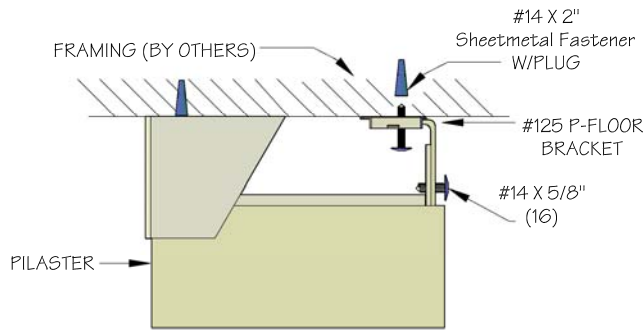

DETAIL A

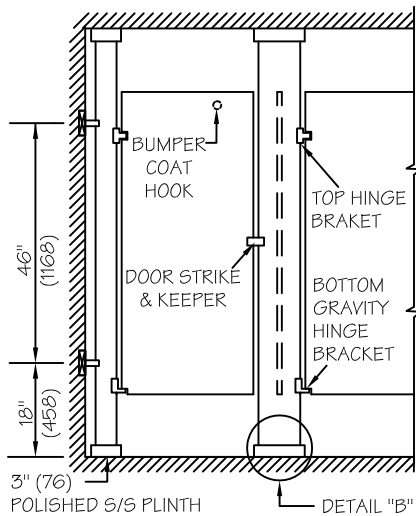

FRONT ELEVATION

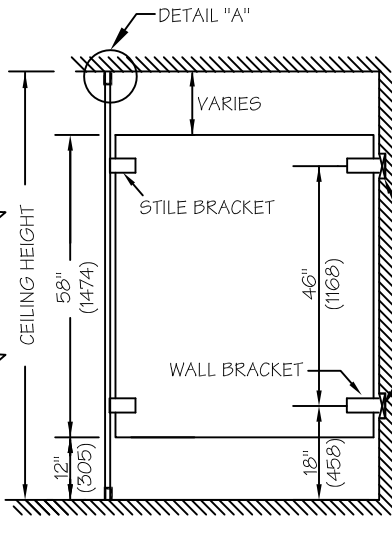

SIDE ELEVATION

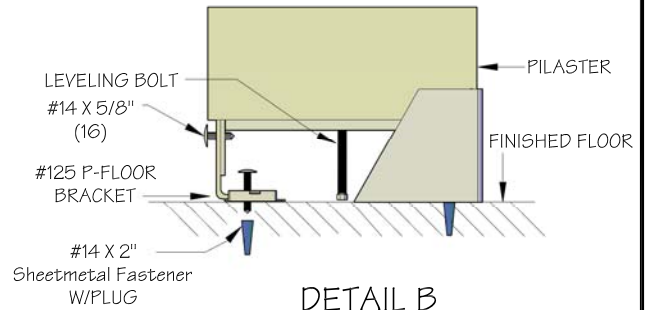

DETAIL B

Blocking (by others) shown for standard CPZ stirrup brackets. for full height or any other bracket, consult with Metpar distributors for blocking information and locations.

NOTES: This drawing is a standard detail intended to show general information. See shop drawings for actual job layout and specific job conditions that supercede any conflicting information on this sheet.

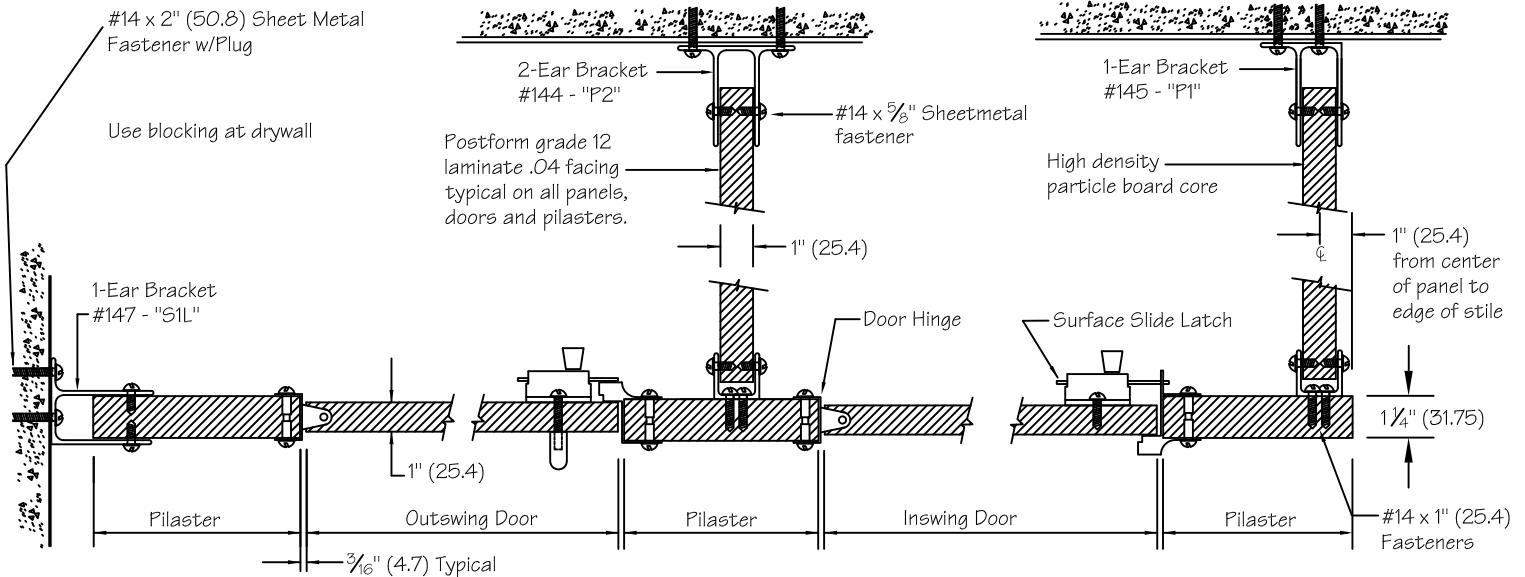

METPAR CORP

95 State Street, Westbury, NY 11590
 Tel: 516-333-2600 Fax: 516-333-2618
 www.Metpar.com ~ Sales@Metpar.com

PLASTIC LAMINATE

SPECIAL DETAIL FP BOTTOM FP TOP
 FLOOR TO CEILING

FCFPFPPL.DWG

12/08/2018